

450S2

ACCESSORIES AVAILABLE / ACCESORIOS DISPONIBLES / ACCESSOIRES DISPONIBLES

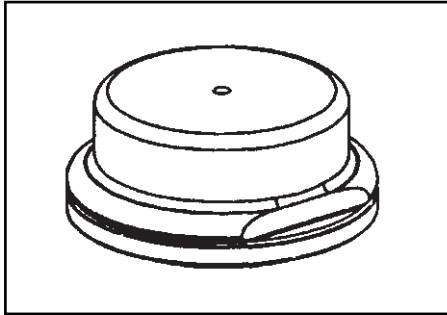

95

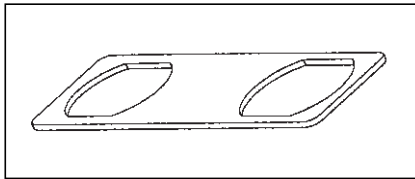

94

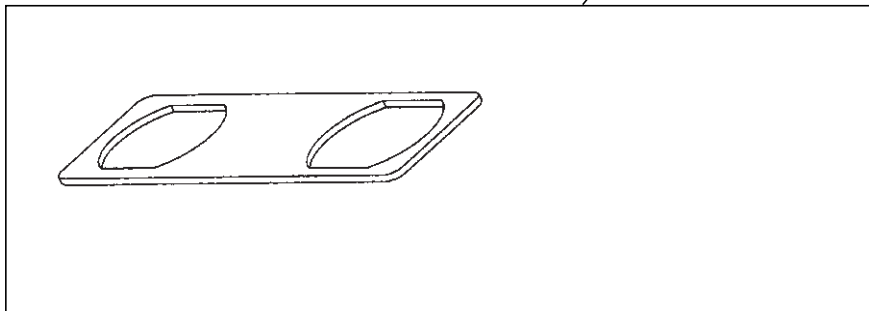

93

BOSTITCH®

450S2

**PNEUMATIC STAPLER
ENGRAPADORA NEUMÁTICA
AGRAFEUSE PNEUMATIQUE**



**TOOL PARTS ILLUSTRATION
ILUSTRACIÓN DE LAS PIEZAS DE LA HERRAMIENTA
ILLUSTRATION DES PIÈCES D'OUTILLAGE**

⚠ WARNING:

⚠ ADVERTENCIA:

⚠ ATTENTION:

BEFORE PERFORMING REPAIRS ON THIS TOOL, ALL OPERATORS SHOULD STUDY THIS ILLUSTRATION, AS WELL AS THE PARTS LIST AND OPERATION AND MAINTENANCE MANUAL. OPERATORS SHOULD UNDERSTAND AND FOLLOW ALL SAFETY WARNINGS AND INSTRUCTIONS. KEEP THIS ILLUSTRATION WITH THE TOOL FOR FUTURE REFERENCE. IF YOU HAVE ANY QUESTIONS, CONTACT YOUR BOSTITCH REPRESENTATIVE DISTRIBUTOR.

ANTES DE LLEVAR A CABO CUALQUIER REPARACIÓN EN LA HERRAMIENTA, TODOS LOS OPERARIOS DEBERÁN ESTUDIAR ESTA ILUSTRACIÓN, ASÍ COMO LA LISTA DE PIEZAS Y EL MANUAL DE OPERACIÓN Y MANTENIMIENTO. LOS OPERARIOS DEBERÁN ENTENDER Y SEGUIR TODAS LAS ADVERTENCIAS E INSTRUCCIONES DE SEGURIDAD. CONSERVE ESTA ILUSTRACIÓN CON LA HERRAMIENTA PARA PODER CONSULTARLA EN LO FUTURO. SI TUVIERA ALGUNA PREGUNTA, PÓNGASE EN CONTACTO CON SU REPRESENTANTE O DISTRIBUIDOR DE BOSTITCH.

AVANT DE PROCÉDER À LA RÉPARATION DE CET OUTIL, LES OPÉRATEURS DOIVENT ÉTUDIER LA PRÉSENTE ILLUSTRATION AINSI QUE LA LISTE DE PIÈCES ET LE MANUEL D'INSTRUCTIONS ET D'ENTRETIEN ; ILS DOIVENT ÉGALEMENT COMPRENDRE ET OBSERVER LES CONSIGNES DE SÉCURITÉ ET LES INSTRUCTIONS. CONSERVER CETTE ILLUSTRATION AVEC L'OUTIL POUR RÉFÉRENCE FUTURE. SI VOUS AVEZ DES QUESTIONS, COMMUNIQUEZ AVEC VOTRE REPRÉSENTANT OU VOTRE DISTRIBUTEUR DE BOSTITCH.

BOSTITCH®
STANLEY FASTENING SYSTEMS L.P.

IP1111-1REVJ 2/07

100279	0002	O-RING,1.612X.103
101525	0003	VALVE,ENERGY CONTROL
102044	0004	PIN,SPIROL 3MMX16MM
102166	0005	LABEL,MAGAZINE CAPACITY
102168	0006	SCREW,SPECIAL (MAGAZINE)
TVA12	0007	KIT,STANDARD MODULE
103208	0008	TUBE,EXHAUST
103211	0009	SEAL,CHECK
103214	0010	DRIVER,(1IN)
103217	0011	BRACKET,MAGAZINE
103218	0012	BUSHING,TOGGLE PIN
103222	0013	PUSHER (1IN)
103447	0014	TOGGLE,MAGAZINE
103549	0015	SPRING,COVER
103558	0016	LATCH,MAGAZINE
103601	0017	SLEEVE,BRACKET
103770	0018	SPRING,COMPRESSION
103791	0019	HANDLE,PUSHER
103795	0020	DISC,LATCH STOP
103858	0021	PIN,SPRING,4X20MM
103993	0022	BUMPER, TOP L/P
103994	0023	PISTON
103995	0024	CAP,SLEEVE L/P
166045	0025	RING,PISTON
103997	0026	SLEEVE,CYLINDER-L/P
103998	0027	BUMPER,LOWER L/P (1")
103999	0028	BULKHEAD,SLEEVE - L/P
104027	0029	COVER,TRIP L/P
104064	0030	PROTECTOR,FRONT FRAME L/P
104067	0031	BUSHING,MAGAZINE COVER
160198	0032	NOSE,S2
104339	0033	ADJUSTER,TRIP
104623	0034	ARM,UPPER CONTACT
104931	0035	CASTING,NOSE COVER
104974	0036	WEARPLATE (1IN)
104975	0037	PLATE,NOSE
105057	0038	GASKET,END CAP L/P
105070	0039	EXHAUST DEFLECTOR
105073	0040	COVER,MAGAZINE
105163	0041	ARM,CONTACT
105797	0042	LABEL
105932	0043	ARM GUIDE ASSEMBLY
105934	0044	SPRING,COMPRESSION
105959	0045	WASHER,PISTON
106051	0046	SPRING,EXTENSION
MHE5080-100	0047	NUT,NYLON M5X.80

MHE6100-100	0048	NUT,ESN M6X1
106058	0049	PIN,SPRING,M3X32
106059	0050	PIN,ROLL,M4X30MM
106097	0051	LABEL,PATENT
158612	0052	LABEL,WARNING
106172	0053	ASSEMBLY,MAGAZINE,2IN
166984	0054	FRAME
106292	0055	CAP,END L/P
106334	0056	PIN,SPIRAL 4X10MM
106474	0057	TOP GUIDE
106691	0058	WASHER,SPECIAL M6
106871	0059	PIN,SPRING 4X32MM
107071	0060	TIP,CORE (2")
107129	0061	O-RING,.268X.075
850607	0062	O-RING,1.484X.139
850628	0063	O-RING,1.734X.139
851554	0064	O-RING,.703X.103
MLW50065		WASHER,HSLW M5
MPG030012	0066	PIN,SPRING,M3X12MM
MSC5080-20	0067	SCREW,SOC HD. CAP M5 X 20
MSC6100-35	0068	SCREW,SHCS,M6X1.00X35
CNTK2	0069	KIT,CONTACT TRIP CONVERSION
T50078	0070	ANCHOR,PUSHER SPRING
T60024	0071	PIN,SPECIAL(MAG NUT)
104069	0072	PIN,NOSE
SEQ6	0076	KIT,SEQUENTIAL
110009	0081	LABEL,POWER VALVE
106173	0083	STOP,TRIGGER
105996	0084	O-RING,.087X.059
102164	0086	O-RING,.728X.059
102163	0087	O-RING,.591X.059
167205	0088	ASSEMBLY,HEAD VALVE
101540	0089	SPRING,COMPRESSION
101533	0090	SEAL,EXHAUST
101532	0091	SEAL,HEAD VALVE
102197	0092	O-RING,1.174 X .103
108212	0093	ASSY,400/500 SERIES S2 LM
106427	0094	WRENCH,SLEEVE CAP
112604	0095	CAP,WEIGHT-L/P